



## SPECIFICATION

宏致電子股份有限公司

桃園縣中壢市東園路13號

No.13, Dongyuan Rd., Jhongli City,

Taoyuan County 320, Taiwan (R.O.C.)

TEL: +886-3-463-2808

FAX: +886-3-463-1800

SPEC. NO.: PS-51206-XXXXX-XXX REVISION: F

PRODUCT NAME: 2.0 mm PITCH WIRE TO BOARD WAFER CONNECTOR

PRODUCT NO: 51206、51313、51312、51310、87371 SERIES

PREPARED:  <b>Zhu,SiBiao</b>  DATE: <b>2024.01.24</b>	CHECKED:  <b>Lu,Jing Quan</b>  DATE: <b>2024.01.24</b>	APPROVED:  <b>hsieh,fu yu</b>  DATE: <b>2024.01.24</b>
--	---	---



**TITLE: 2.0 mm PITCH WIRE TO BOARD WAFER**

RELEASE DATE: 2024.01.24

REVISION:F

ECN No: ECN-008566

PAGE: **2** OF **17**

1	REVISION HISTORY .....	3
2	SCOPE .....	4
3	APPLICABLE DOCUMENTS.....	4
4	REQUIREMENTS.....	4
5	PERFORMANCE .....	5
6	PRODUCT QUALIFICATION AND TEST SEQUENCE.....	8
7	MATING / UNMATING FORCES.....	9
8	APPLICABLE WIRES .....	10
9	WIRE STRIP (INSULATION).....	10
10	STRIP LENGTH.....	10
11	BEND AND TWIST .....	10
12	ROLLING .....	11
13	BELL-MOUTH.....	11
14	CARRIER CUT OFF LENGTH .....	11
15	STRANDED CONDUCTORS INSERTED LENGTH.....	12
16	INSULATION POSITION .....	13
17	STANDARD INSULATION CRIMP .....	14
18	INSULATION CRIMP HEIGHT .....	14
19	ABOUT CRIMP HEIGHT (CONDUCTORS CRIMP SECTION) .....	15
20	CRIMP HEIGHT MEASUREMENT .....	15
21	PULL FORCE OF CRIMP SECTION MEASUREMENT.....	16
22	TABLE OF STRIP LENGTH, BEND, TWIST, ROLLING ANGLES, CUT OFF, AND EXTRUDE LENGTH.....	16
23	TABLE OF APPLICABLE WIRES, CRIMP HEIGHT, AND PULL FORCE .....	17

TITLE: **2.0 mm PITCH WIRE TO BOARD WAFER**

RELEASE DATE: 2024.01.24

REVISION:F

ECN No: ECN-008566

PAGE: 3 OF 17

## 1 Revision History

Rev.	ECN NO.	Revision Description	Prepared	Date
1	ECN-1505324	NEW SPEC FOR 51206	GUKEQING	2015.05.27
O	ECN-1510055	ADD Working voltage AND Voltage Rating	GUKEQING	2015.10.09
A	ECN-1601351	ADD 51313 51312 SERIES	GUKEQING	2016.01.28
B	ECN-1701161	ADD 51310 SERIES	LLJ	2017.01.14
C	ECN-1705244	ADD 2PIN,3PIN,11PIN, Mating / Unmating Forces	LLJ	2017.05.12
D	ECN-1803093	ADD 87371 SERIES	Huang ,Shun Sen	2018.03.07
E	ECN-1808263	ADD Salt Spray Standard	Chai ,Yun he	2018/08/14
F	ECN-008566	CHANGE CRIMP HEIGHT AND CRIMP WIDTH IN ITEM 23	Zhu ,Si Biao	2024/01/24

TITLE: **2.0 mm PITCH WIRE TO BOARD WAFER**

RELEASE DATE: 2024.01.24

REVISION:F

ECN No: ECN-008566

PAGE: 4 OF 17

## 2 Scope

This specification covers performance, tests and quality requirements for 2.0mm Wire to Board wafer SMT T/H Type. These connectors are this Product SPEC.refer to Aces's P/N: 51206、51312、51313、51310、87371 series.

## 3 Applicable documents

EIA-364: ELECTRONICS INDUSTRIES ASSOCIATION

## 4 Requirements

### 4.1 Design and Construction

Product shall be of design, construction and physical dimensions specified on applicable product drawing.

### 4.2 Materials and Finish

4.2.1 Contact: High performance copper alloy

4.2.2 Finish: Refer to the drawing

4.2.3 Housing: Thermoplastic or Thermoplastic High Temp., UL94V-0

### 4.3 Ratings

4.3.1 Working voltage less than 36 volts AC (per pin)

4.3.2 Voltage Rating: 250V AC/DC

4.3.3 Current Rating: AWG#30 1.0A AC/DC

AWG#28 1.5A AC/DC

AWG#26 2.0A AC/DC

AWG#24 2.5A AC/DC

AWG#22 3.0A AC/DC

4.3.4 Temperature Rating: -25°C to +105°C

TITLE: **2.0 mm PITCH WIRE TO BOARD WAFER**

RELEASE DATE: 2024.01.24

REVISION:F

ECN No: ECN-008566

PAGE: **5** OF **17**

## 5 Performance

### 5.1. Test Requirements and Procedures Summary

Item	Requirement	Standard
Examination of Product	Product shall meet requirements of applicable product drawing and specification.	Visual, dimensional and functional per applicable quality inspection plan.
<b>ELECTRICAL</b>		
Item	Requirement	Standard
Low Level Contact Resistance	20 m $\Omega$ Max.(initial)per contact 30 m $\Omega$ Max. Change allowed	Mate connectors, measure by dry circuit, 20mV Max., 10mA Max. (EIA-364-23)
Insulation Resistance	500 M $\Omega$ Min.	Unmated connectors, apply 500 V DC between adjacent terminals. (EIA-364-21)
Dielectric Withstanding Voltage	No discharge, flashover or breakdown. Current leakage: 1 mA max	1000 VAC/Minute. at sea level for 1 minute. Test between adjacent contacts of unmated connectors. (EIA-364-20)
Temperature rise	30°C Max. Change allowed	Mate connector: measure the temperature rise at rated current until temperature stable. The ambient condition is still air at 25°C (EIA-364-70 METHOD 1,CONDITION 1)
<b>MECHANICAL</b>		
Item	Requirement	Standard
Durability	30 cycles.	The sample should be mounted in the tester and fully mated and unmated the number of cycles specified at the rate of 25.4 $\pm$ 3mm/min. (EIA-364-09)
Crimp Pull out force	1.0 Kgf Min.	Operation Speed : 25.4 $\pm$ 3 mm/minute.. Measure the force required to mate/Un-mate connector. (EIA-364-13)
Mating / Un-mating Forces	See item 7	Operation Speed : 25.4 $\pm$ 3 mm/minute.. Measure the force required to mate/Un-mate connector. (EIA-364-13)

TITLE: **2.0 mm PITCH WIRE TO BOARD WAFER**

RELEASE DATE: 2024.01.24

REVISION:F

ECN No: ECN-008566

PAGE: **6** OF **17**

Contact Retention Force (Board Side)	0.8kgf MIN.	Operation Speed : 25.4 ± 3 mm/minute. Measure the contact retention force with Tensile strength tester
Terminal / Housing Retention Force (Cable Side)	0.7kgf MIN.	Apply axial pull out force at the speed rate of 25.4 ± 3 mm/minute. On the terminal assembled in the housing.
Fitting Nail /Housing Retention Force	0.35kgf MIN.	Apply axial pull out force at the speed rate of 25.4 ± 3 mm/minute. On the fitting nail assembled in the housing.
Locking Force	2kgf MIN	While withdrawing plug & receptacle Without terminal at speed 25.4 ± 3 mm/minute
Vibration	1 μs Max.	The electrical load condition shall be 100 mA maximum for all contacts. Subject to a simple harmonic motion having amplitude of 0.76mm (1.52mm maximum total excursion) in frequency between the limits of 10 and 55 Hz. The entire frequency range, from 10 to 55 Hz and return to 10 Hz, shall be traversed in approximately 1 minute. This motion shall be applied for 2 hours in each of three mutually perpendicular directions. (EIA-364-28 Condition I)
Shock (Mechanical)	1 μs Max.	Subject mated connectors to 50 G's (peak value) half-sine shock pulses of 11 milliseconds duration. Three shocks in each direction shall be applied along the three mutually perpendicular axes of the test specimen (18 shocks). The electrical load condition shall be 100mA maximum for all contacts. (EIA-364-27, test condition A)

TITLE: **2.0 mm PITCH WIRE TO BOARD WAFER**

RELEASE DATE: 2024.01.24

REVISION:F

ECN No: ECN-008566

PAGE: 7 OF 17

## ENVIRONMENTAL

Item	Requirement	Standard
Resistance to Reflow Soldering Heat	See Product Qualification and Test Sequence Group 9(Lead Free)	Solder Temp: 265±5°C, 10±0.5sec.
Thermal Shock	See Product Qualification and Test Sequence Group 4	Mate module and subject to follow condition for 5 cycles. 1 cycles: -55 +0/-3 °C, 30 minutes +85 +3/-0 °C, 30 minutes (EIA-364-32, test condition I)
Humidity	See Product Qualification and Test Sequence Group 4	Mated Connector 40°C, 90~95% RH, 96 hours. (EIA-364-31,Condition A, Method II)
Temperature life	See Product Qualification and Test Sequence Group 5	Subject mated connectors to temperature life at 85°C for 96 hours. (EIA-364-17, Test condition A)
Salt Spray (Only For Gold Plating)	See Product Qualification and Test Sequence Group 6	Subject mated/unmated connectors to 5% salt-solution concentration, 35°C 1). Gold Flash for 8 hours. 2). Gold Plating 3u” for 48 hours. 3). Gold Plating 5u” (Min) for 96 hours. (EIA-364-26)
Solder ability	Tin plating: Solder able area shall have minimum of 95% solder coverage. Gold plating: Solder able area shall have minimum of 75% solder coverage	Subject the test area of contacts into the flux for 5-10 sec. And then into solder bath, Temperature at 245 ±5°C, for 4-5 sec. (EIA-364-52)
Hand Soldering Temperature Resistance	Appearance: No damage	T ≥ 350°C, 3sec at least.

**Note.** Flowing Mixed Gas shall be conduct by customer request.  
Infrared reflow condition

TITLE: **2.0 mm PITCH WIRE TO BOARD WAFER**

RELEASE DATE: 2024.01.24

REVISION:F

ECN No: ECN-008566

PAGE: 8 OF 17

## 6 Product qualification and test sequence

Test or Examination	Test Group										
	1	2	3	4	5	6	7	8	9	10	11
	Test Sequence										
Examination of Product				1、7	1、6	1、4			1		1
Low Level Contact Resistance		1、5	1、4	2、10	2、9	2、5			2		
Insulation Resistance				3、9	3、8						
Dielectric Withstanding Voltage				4、8	4、7						
Temperature rise	1										
Mating / Un-mating Forces		2、4									
Durability		3									
Crimp pull out force										1	
Locking Force										1	
Vibration			2								
Shock (Mechanical)			3								
Thermal Shock				5							
Humidity				6							
Temperature life					5						
Salt Spray(Only For Gold Plating)						3					
Solder ability							1				
Fitting Nail /Housing Retention Force								3			
Contact Retention Force (Board Side)								1			
Terminal/Housing Retention Force (Cable Side)								2			
Resistance to Soldering Heat									3		
Hand Soldering Temperature Resistance											2
Sample Size	2	4	4	4	4	4	2	5	4	5	4



TITLE: **2.0 mm PITCH WIRE TO BOARD WAFER**

RELEASE DATE: 2024.01.24

REVISION:F

ECN No: ECN-008566

PAGE: **9** OF **17**

### 7 Mating / Unmating Forces

NO. OF Ckt.	At Initial		At 30th
	Mating(kgf max)	Un-mating(kgf min)	Un-mating(kgf min)
2	2.00	0.30	0.20
3	2.00	0.30	0.20
4	2.50	0.30	0.20
5	3.00	0.30	0.30
6	3.00	0.30	0.30
7	3.00	0.30	0.30
8	4.00	0.40	0.40
9	4.00	0.40	0.40
10	4.00	0.40	0.40
11	5.00	0.50	0.50
12	5.00	0.50	0.50

TITLE: **2.0 mm PITCH WIRE TO BOARD WAFER**

RELEASE DATE: 2024.01.24

REVISION:F

ECN No: ECN-008566

PAGE: **10** OF **17**

### 8 Applicable wires

It will depend on selected terminals. Please refer to terminal specification to select wires.  
(Refer to sec 18.0)

### 9 Wire strip (Insulation)

Please be careful when cut wire insulation. If some stranded conductors were cut, the termination may not meet the specified pull force.

### 10 Strip length

Strip length depends on wire barrel size. Please refer to terminal specification to cut correct strip length. (Refer to sec 18.0)

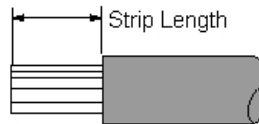

### 11 Bend and twist

#### 11.1 BEND UP AND DOWN

Maximum bend up down angles please refer to terminal specification. If bend angles larger than specified, terminals will difficult insert to housing or retention force (terminal and housing) may not meet the specified. (Refer to sec 17.0)

#### 11.2 TWIST

Maximum twist angles please refer to terminal specification. If larger than specified, terminals will difficult insert to housing or retention force (terminal and housing) may not meet the specified.  
(Refer to sec 17.0)

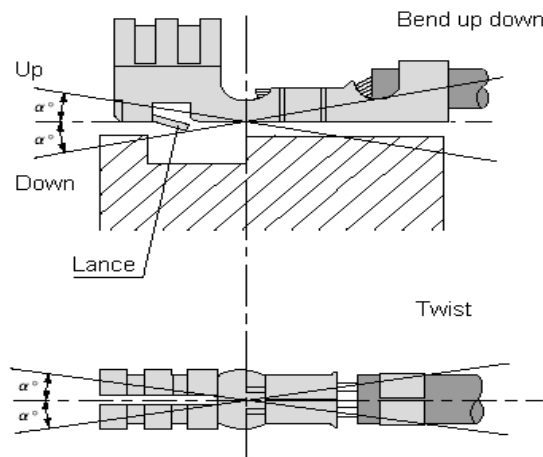

## 12 Rolling

Centerline of wire crimped should be near contact centerline. If twisted, the termination may not meet the specified pull force or non-stable. (Refer to sec 17.0)

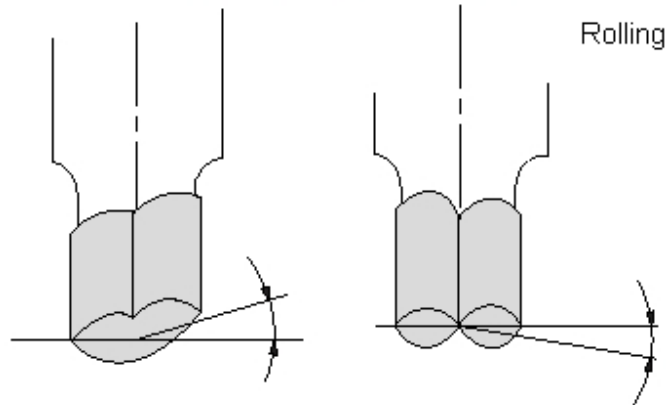

## 13 Bell-mouth

Bell-mouth is needed, please be care. If no or undersized bell-mouth after crimped, it will cause some of stranded conductors broken and the termination may not meet the specified pull force. Recommended bell-mouth size approximate 2X material thickness. (Refer to sec 17.0)

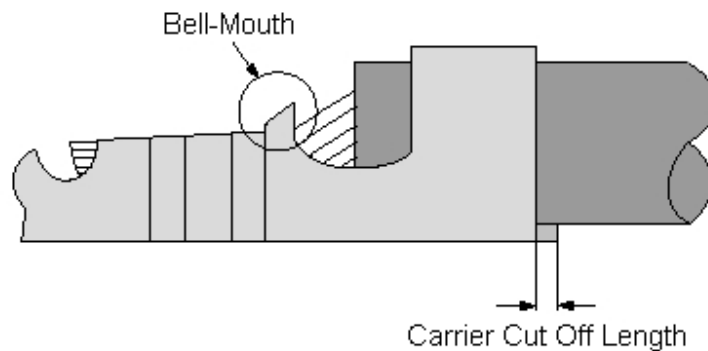

## 14 Carrier cut off length

It is possible cause performance lower if cut length is too long. Carrier cut length as above figure shown. Recommended cut off length approximate 1.5X material thickness maximum. (Refer to sec 18.0)

### 15 Stranded conductors inserted length

If stranded conductors are inserted too far into the crimp sections, this may cause some problems when terminal inserted into housing.

If stranded conductor's inserted length is too short, the termination may not meet the specified pull force because the metal-to-metal contact between the wire and the terminal is reduced.

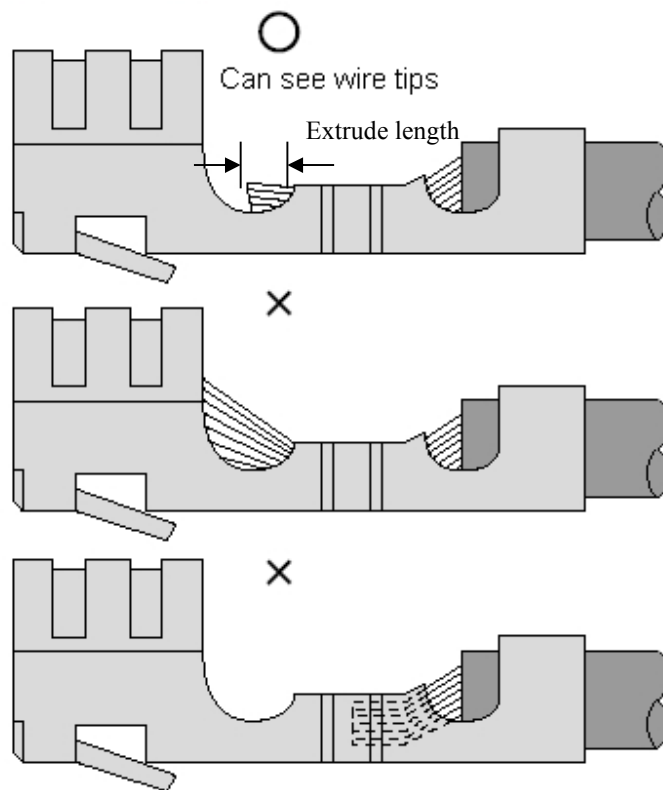

### 16 Insulation position

The ideal position of insulation tip is visible as following figure shown. If insulation were into crimp section, may cause unstable conduction. If too short, may not meet the specified pull force.

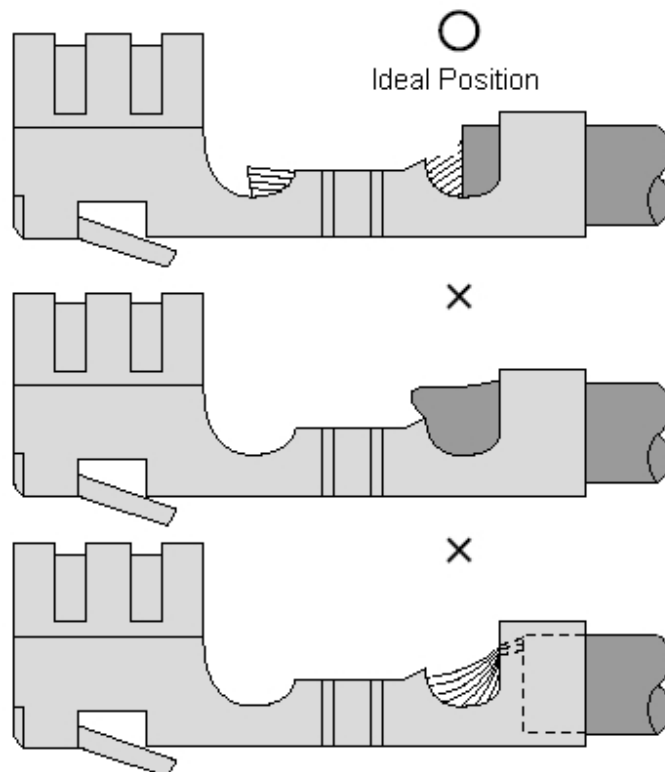

### 17 Standard insulation crimp

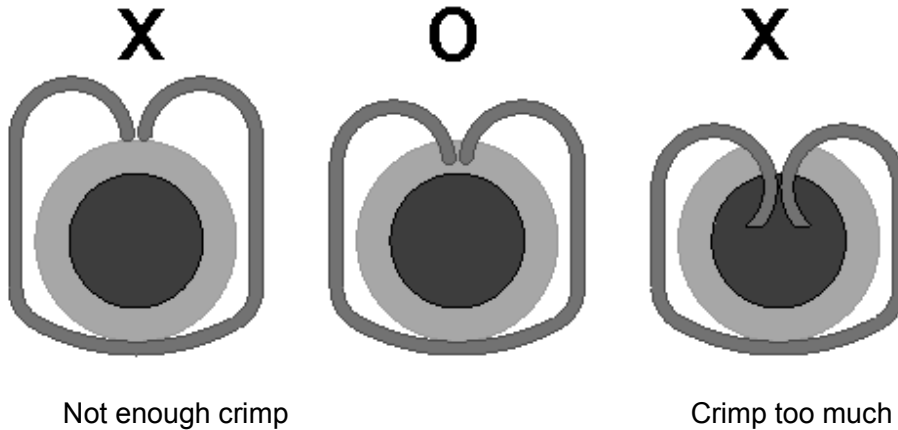

### 18 Insulation crimp height

Insulation crimp height depends on wire diameter.

- 5.1 As following figure 1 shown. It is no problem if wire bent up down 90 degrees 1 cycle and insulation position still in ideal position.
- 5.2 For longer strip length case, insulation crimp height as following figure 2 shown. The crimp height avoids stranded conductors be damaged.

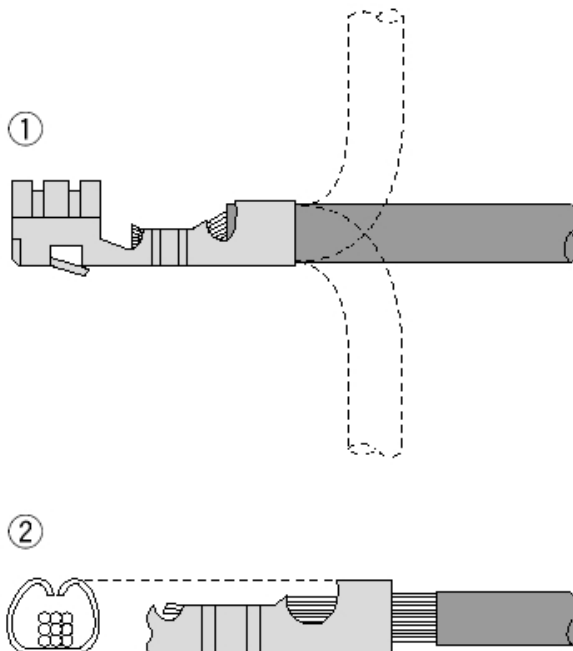

TITLE: **2.0 mm PITCH WIRE TO BOARD WAFER**

RELEASE DATE: 2024.01.24

REVISION:F

ECN No: ECN-008566

PAGE: **15** OF **17**

**19 About crimp height (Conductors crimp section)**

Crimp height is an important control dimension in the process. It depends on terminal types and applied wire sizes. Please refer to terminal specification for more detail. (Refer to sec 18.0)

**20 Crimp height measurement**

Please use micrometer to measure crimp height as following figure shown. And selected crimp section center to measure.

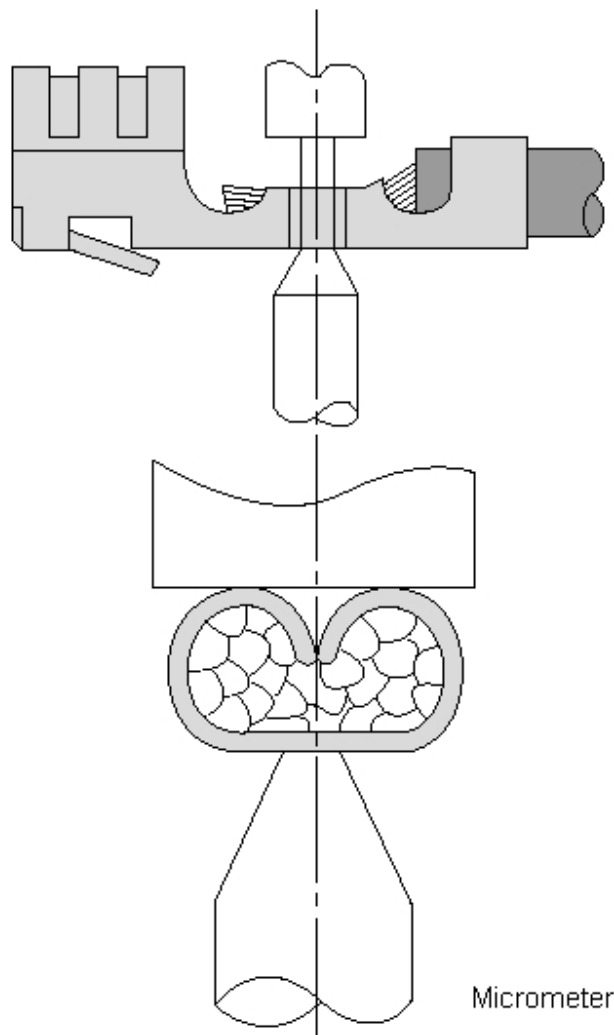

Micrometer

### 21 Pull force of crimp section measurement

Make some test samples as following figure shown. Use a typical tensile test machine or pull gage to pull cable at a speed 25mm/min. And read the force when cable withdrew from crimp section or braked.

Before test samples, please measure crimp height and do not crimp insulation.

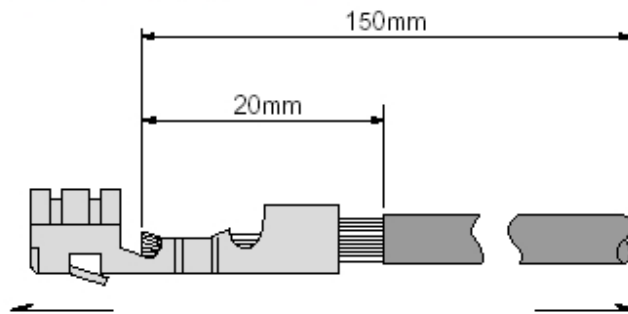

### 22 Table of strip length, bend, twist, rolling angles, cut off, and extrude length

Product Description	Product No.	Strip length (mm)	Max. Bend		Max. Twist	Max. Rolling	Bell-Mouth (mm)	Cut Off (mm)	Extrude length (mm)
			Up	Down					
2.0 MM PITCH WTB Terminal	51206-Txxx	1.80~2.30	6°	6°	5°	7°	0.1 ~ 0.3	0.0 ~ 0.3	0.05 ~ 0.20

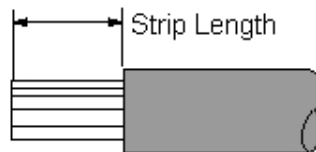



TITLE: **2.0 mm PITCH WIRE TO BOARD WAFER**

RELEASE DATE: 2024.01.24

REVISION:F

ECN No: ECN-008566

PAGE: 17 OF 17

**23 Table of applicable wires, crimp height, and crimp width**

Product Description	Product No.	Wire		Crimp Height (mm)(REF.)		Crimp Width (mm) (REF.)	
		AWG Size	Insulation D (mm)	Conductor A	Insulation B	Conductor W1	Insulation W2
2.0 MM PITCH WTB Terminal	51206-Txxx	UL10368 #22	1.30	0.95Max.	1.50 Max.	1.35 Max.	1.40 Max
		UL10368 #24	1.15	0.80Max.	1.50 Max.	1.35 Max.	1.40 Max
		UL10368 #26	1.02	0.65Max.	1.50 Max.	1.35 Max.	1.40 Max
		UL10368 #28	0.92	0.60Max.	1.40 Max.	1.25 Max.	1.30 Max
		UL10368 #30	0.82	0.55Max.	1.40 Max.	1.25 Max.	1.30 Max

